



# Data Sheet

## Powertip alphanumeric dot matrix liquid crystal displays

Reflective types - RS stock numbers 214-3238, 214-3244, 214-3250, 214-3266, 214-3272, 214-3288, 214-3294, 214-3301, 214-3317, 214-3323, 214-3339, 214-3345, 214-3351, 294-8667, 294-8689, 294-8695, 294-8702, 294-8718, 294-8724, 294-8746, 294-8752

EL types - RS stock numbers 214-3367, 214-3373, 214-3395, 214-3402, 214-3418

LED types - RS stock numbers 214-3480, 214-3496, 214-3519, 214-3525, 214-3531, 214-3547, 214-3553, 214-3569, 214-3575, 215-3617, 294-8774, 294-8780, 294-8796, 294-8803, 294-8819

Intelligent, alphanumeric, dot matrix modules with integral CMOS microprocessor and LCD display drivers. The modules utilise a  $5 \times 7$  dot matrix format with cursor, and are capable of displaying 192 different alphanumeric characters and symbols. The modules are available in twisted nematic and super twisted nematic grey mode. Reflective types are available in TN and STN, EL backlit types in TN, LED backlit transmissive types in TN LED backlit transreflective types in STN. Inverters are required to drive the EL backlit types.

### Applications

- Data terminals
- Medical instruments
- Hand-held instruments
- Hand-held data terminals
- Electronic typewriters
- Point of sale terminals
- Test instruments
- Word processors.

### Features

- Single 5V power supply (excluding EL types)
- Wide viewing angle (STN)
- High contrast
- Interfaces to a 4 or 8-bit data bus
- ASC11 compatible
- Chip-on-board technology (COB)
- 192 different characters and symbols
- 8 user programmable characters
- Compact and lightweight
- Low power consumption
- Surface mounted components (SMT).
- Powerful instruction set



### ATTENTION

OBSERVE PRECAUTIONS  
FOR HANDLING

ELECTROSTATIC  
SENSITIVE  
DEVICES

## Absolute maximum rating

Item	Symbol	Value	Unit
Power supply voltage	Vdd - Vss	-0.3 ~ + 7.0	V
Driver supply voltage	Vlcd	Vdd - 13.5 ~ Vdd +0.3	
Input voltage	Vin	-0.3 ~ Vdd +0.3	
Operating temperature range	Top	0 ~ +50	°C
Storage temperature range	Tst	-20 ~ +60	

## Description of terminals

Symbol	Input/Output	External connection	Function	
RS	Input	MPU	<b>Register selection input</b>	
			<table border="1"> <tr> <td>High</td> <td>Data register (for read and write)</td> </tr> <tr> <td>Low</td> <td>Instruction register (for write), Busy flag, address counter (for read)</td> </tr> </table>	High
High	Data register (for read and write)			
Low	Instruction register (for write), Busy flag, address counter (for read)			
R/W	Input	MPU	R/W signal input is used to select the read/write mode	
			<table border="1"> <tr> <td>High</td> <td>Read mode</td> </tr> <tr> <td>Low</td> <td>Write mode</td> </tr> </table>	High
High	Read mode			
Low	Write mode			
E	Input	MPU	Start enable signal to read or write the data	
DB4   DB7	Input/Output	MPU	Four high order bidirectional three-state data bus lines. Used for data transfer between the MPU and the LCD module. DB7 can be used as a busy flag.	
DB0   DB3	Input/Output	MPU	Four low order bidirectional three-state data bus lines. Used for data transfer between the MPU and the LCD module. These four are not used during 4-bit operation.	
Vdd  Vss		Power Supply	Vdd : + 5V      Vss : GND	
Vo (Vlcd)		Power Supply	Contrast adjustment voltage Vdd - 11~ Vdd + 0.3	

**Electrical characteristics**

DC characteristics (Vdd = + 5V ± 10%, Vss = 0V, Ta = 25°C)

Parameter	Symbol	Condition	Application PIN	Min.	Type	Max.	Unit
H level input voltage (1)	Vih 1	-	DB0 ~ DB7	2.2	-	Vdd	V
L level input voltage (1)	Vil 1	-	RS, R/W, E	-0.3	-	0.6	V
H level output voltage (1)	Voh 1	Ioh = -0.205mA	DB0 ~ DB7	2.4	-	-	V
L level output voltage (1)	Vol 1	Iol = 1.2mA		-	-	0.4	V
I/o leakage current	Iil	Vin = 0 to Vdd	E	-1	-	1	uA
Pull-UP Mos current	-Ip	Vdd = 5V	RS R/W DB0-DB7	50	125	250	uA
Supply current (Depends on module size)	Iop	RF oscillation, from external clock Vdd = 5v fosc = 270kHz	Vdd	- 1.3	-	0.6 2.5	mA

**Internal clock operation (Rf oscillation)**

Oscillation frequency	fosc	Rf = 91k Ω ± 2%	OSC1   OSC2	190	270	350	kHz
LCD driving voltage	Vlcd	Vdd - V5	V1 ~ V5	3.0	-	11.0	V

**LED Backlight Characteristics (Vf = 4.2Vtyp , 4.8Vmax. this figure must not be exceeded)**

RS Part Number	Condition	Symbol	Type	Max.	Unit
214-3480	Ta=25°C	f	70	140	mA
214-3496	Ta=25°C	f	80	160	mA
294-8796	Ta=25°C	f	190	380	mA
214-3519, 214-3525 294-8774	Ta=25°C	f	120	240	mA
294-8803, 214-3531	Ta=25°C	f	360	700	mA
294-8819, 214-3474, 214-3575	Ta=25°C	f	270	500	mA
214-3553	Ta=25°C	f	40	80	mA
214-3569	Ta=25°C	f	150	300	mA
215-3617	Ta=25°C	f	440	800	mA
214-3547, 294-8780	Ta=25°C	f	210	420	mA

**AC characteristics (Vdd = 5V ± 10%, Vss = 0V, Ta = 25°C) Read cycle (Figure 6)**

Parameter	Symbol	Min.	Type	Max.	Unit	Test PIN
Enable cycle time	tc	500	-	-	ns	E
Enable "H" level pulse width	tw	220	-	-	ns	E
Enable rise/fall time	tr,tf	-	-	25	ns	E
RS, R/W setup time	tsu	40	-	-	ns	R/W, RS
RS, R/W address hold time	th	10	-	-	ns	R/W, RS
Read data output delay	td	-	-	120	ns	DB0 ~ DB7
Read data hold time	tdh	20	-	-	ns	DB0 ~ DB7

**Write cycle (Figure 5)**

Parameter	Symbol	Min.	Type	Max.	Unit	Test PIN
Enable cycle time	tc	500	-	-	ns	E
Enable H level pulse width	tw	220	-	-	ns	E
Enable rise/fall time	tr,tf	-	-	25	ns	E
RS, R/W setup time	tsul	40	-	-	ns	R/W, RS
RS, R/W address hold time	th1	10	-	-	ns	R/W, RS
Date setup time	tsu2	60	-	-	ns	DB0 ~ DB7
Write data hold time	th2	10	-	-	ns	DB0 ~ DB7

Optical characteristics

1. STN type

Item	Symbol	Condition	Min.	Typ.	Max.	Unit	Note
Viewing angle	$\phi_2 - \phi_1$	$K = 1.4$	60	-	-	deg.	*1, *2
Contrast ratio	K	$\phi = 10^\circ\text{C}$ $\theta = 0^\circ\text{C}$	5	-	-	-	*3
Response time (rise)	tr	$\phi = 10^\circ\text{C}$ $\theta = 0^\circ\text{C}$	-	150	250	ms	*4
Response time (fall)	tf	$\phi = 10^\circ\text{C}$ $\theta = 0^\circ\text{C}$	-	200	300	ms	*4

2. TN type

Item	Symbol	Condition	Min.	Typ.	Max.	Unit	Note
Viewing angle	$\phi_2 - \phi_1$	$K = 1.4$	40	-	-	deg.	*1, *2
Contrast ratio	K	$\phi = 25^\circ\text{C}$ $\theta = 0^\circ\text{C}$	-	5	-	-	*3
Response time (rise)	tr	$\phi = 25^\circ\text{C}$ $\theta = 0^\circ\text{C}$	-	80	120	ms	*4
Response time (fall)	tf	$\phi = 25^\circ\text{C}$ $\theta = 0^\circ\text{C}$	-	60	90	ms	*4

\*1. Definition of  $\theta$  and  $\phi$

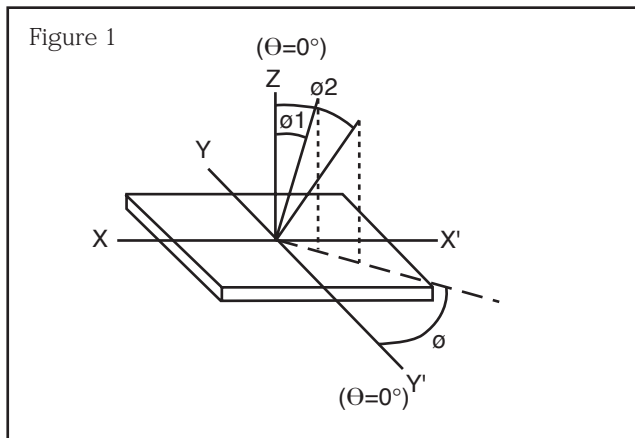

\*3. Definition of contrast ratio

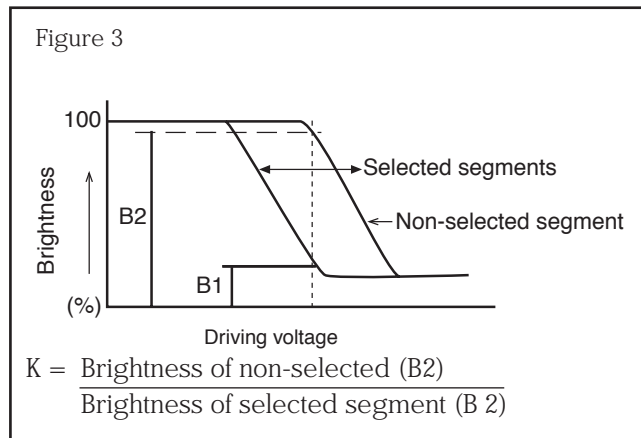

\*2. Contrast vs viewing angle

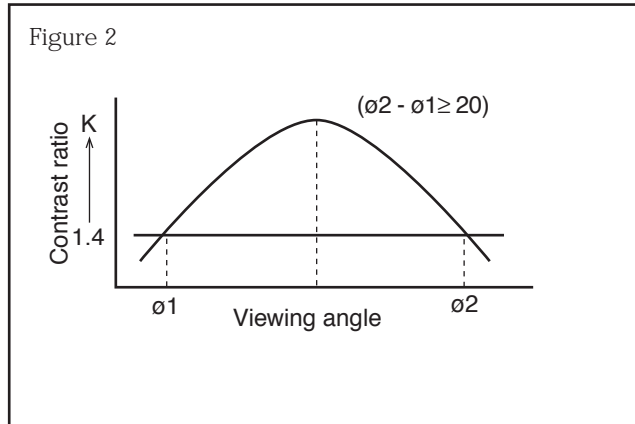

\*4 Definition of optical response

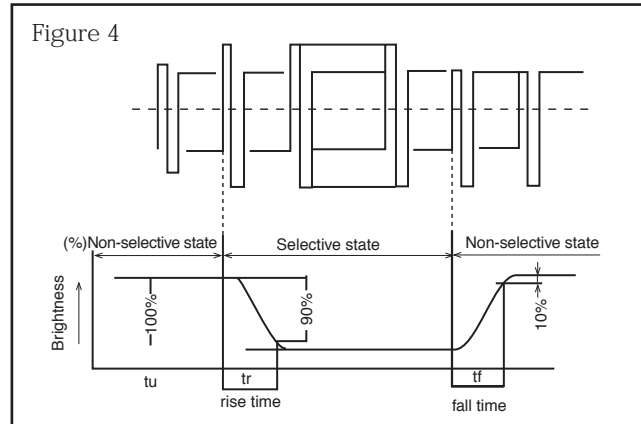

Timing characteristics

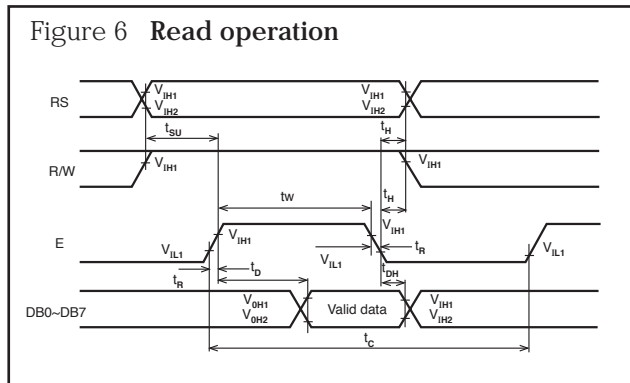
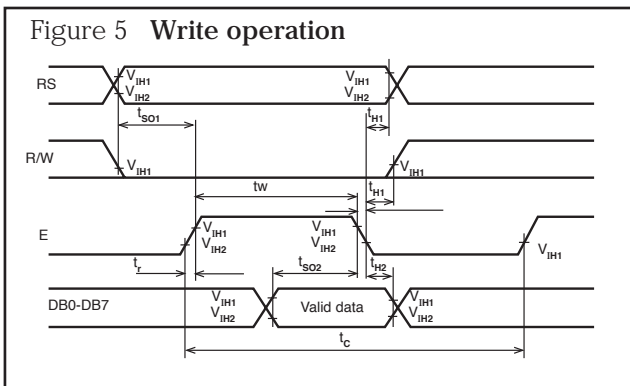

The modules can be interfaced to 4 bit or 8 bit micro controllers (MPU):

4-bit interface

All data/command transfers are made through data bits DB4 to DB7. (Data bits DB0 to DB3 are not used). Each data transfer to the module requires two 4 bit write operations. The 4 high order bits (DB4 to DB7) should be transferred first, while the 4 low order bits (DB0 to DB3) should be transferred last.

8-bit interface

The 8 bit interface uses all 8 line data line (DB0 to DB7).

Example of interface with 8-bit MPU (Z80)

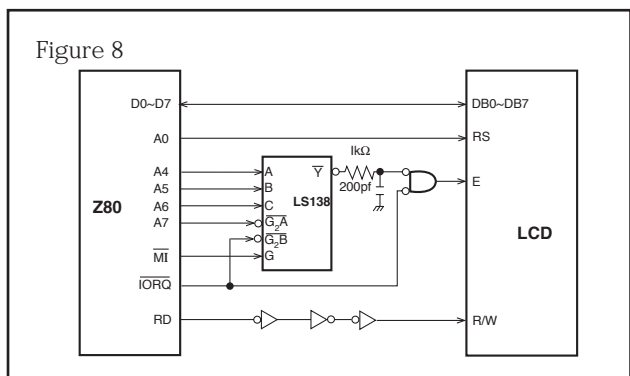
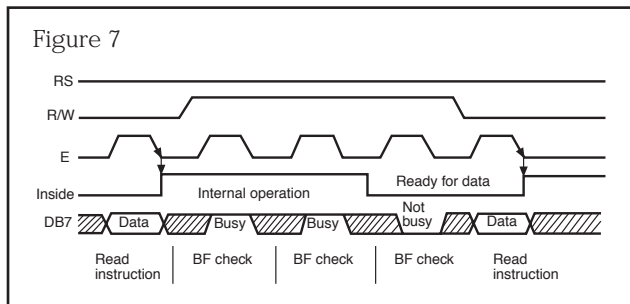

Example of interface with 4-bit MPU

The interface with a 4 bit MPU can be made using through an I/O port. If an 8 bit I/O port is not available a 4 bit I/O port can be used. The module should be initialised to accept 4 bit data and commands. Each command/data instruction must be sent as two 4 bit nibbles, high order nibble first. The busy flag (BF) should be checked every 2 cycles. (Please note that checking the busy flag requires 2 cycles as well).

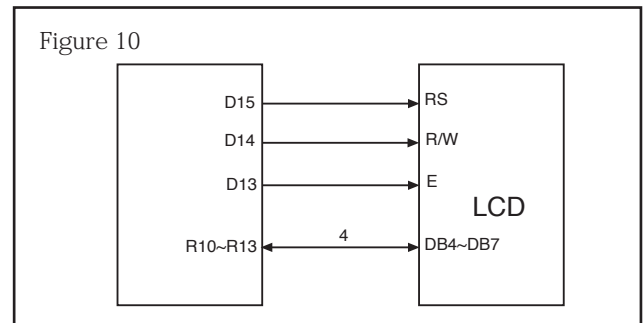
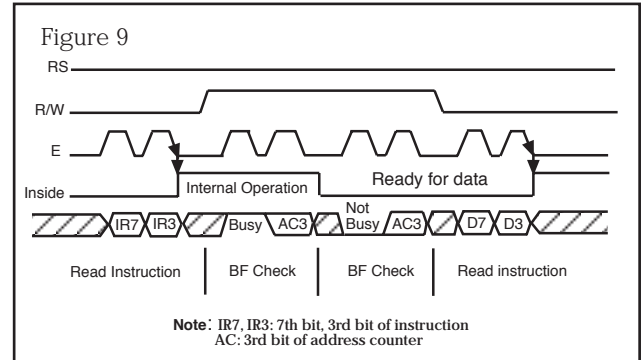

Features

- Interface with 8-bit or 4-bit MPU is available.
- 192 kind of alphabets, numerals, symbols and special characters can be displayed by built-in character generator (ROM).
- Other preferred characters can be displayed by character generator (RAM).
- Various functions of instruction are available by programming.
  - Clear display
  - Cursor at home
  - On/off cursor
  - Blink character
  - Shift display
  - Shift cursor
  - Read/write display data etc.
- Compact and light design which can be easily assembled in devices.
- Single power supply +5 drive (at ambient temperature).
- Low power consumption.

Example of power supply

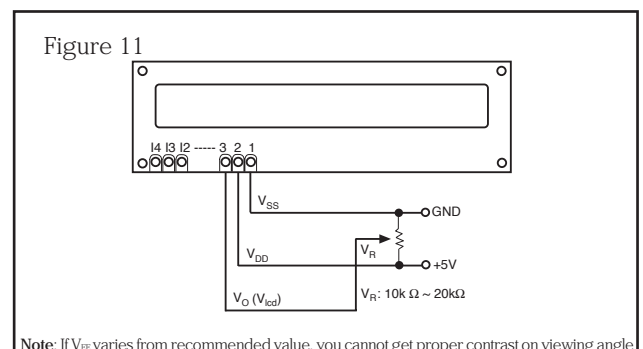

Note: If  $V_{Ee}$  varies from recommended value, you cannot get proper contrast on viewing angle.

Instructions

Instructions	Code										Description	Executed Time (max.)	
	RS	R/W	DB7	DB6	DB5	DB4	DB3	DB2	DB1	DB0			
Clear display	0	0	0	0	0	0	0	0	0	1	Clears the display and returns the cursor to the home position (Address 0)	1.64mS	
Cursor at home	0	0	0	0	0	0	0	0	0	1	* Returns the cursor to the home position (address 0). Also returns the display being shifted to the original position. DDRAM contents remain unchanged.	1.64mS	
Entry mode set	0	0	0	0	0	0	0	1	I/D	S	Sets the cursor move direction and specifies or not to shift the display. These operations are performed during the data write and read.	40μS	
Display On/off control	0	0	0	0	0	0	1	D	C	B	Sets ON/OFF of all display (D) cursor ON/OFF (C), and blink of cursor position character (B).	40μS	
Cursor/display shift	0	0	0	0	0	1	S/C	R/L	*	*	Moves the cursor and shifts the display without changing DDRAM contents.	40μS	
Function set	0	0	0	0	1	DL	N	F	*	*	Sets interface data length (DL) number of display lines (N) and character font (F).	40μS	
CGRAM address set	0	0	0	1	ACG							Set the CGRAM address. CGRAM data is sent and received after this setting.	40μS
DDRAM address set	0	0	1	ADD							Set the DDRAM address. DDRAM data is sent and received after this setting.	40μS	
Busy flag/address read	0	1	BF	AC							Reads busy flag (BF) indicating internal operation is being performed and reads address counter contents.	0μS	
CGRAM/DDRAM data write	1	0	Write data									Writes data into DDRAM or CGRAM.	46μS
CGRAM/DDRAM Data read	1	1	Read data									Reads data from DDRAM or CGRAM.	46μS

Code	Description	Executed time (max.)
I/D=1:Increment I/D=0:Decrement S=1:With display shift S/C=1: Display shift S/C=0: Cursor movement R/L=1: Shift to the right R/L=0: Shift to the left DL=1:8-bit DL=0:4-bit N=1:2 lines N=0:1 line F=1:5 x 10dots F=0.5 x 7dots BF=1: Internal operation is being performed BF=0: Instruction acceptable	DDRAM:Display data RAM CGRAM:Character generator RAM ACG:CGRAM address ADD:DDRAM address corresponds to cursor address. AC: Address counter, used for both DDRAM and CGRAM	fcp or fosc=250kHz However, when frequency changes, execution time also changes Ex If fcp or fosc is 270kHz, $40\mu S \times 250/270 = 37\mu S$
	*Don't care	

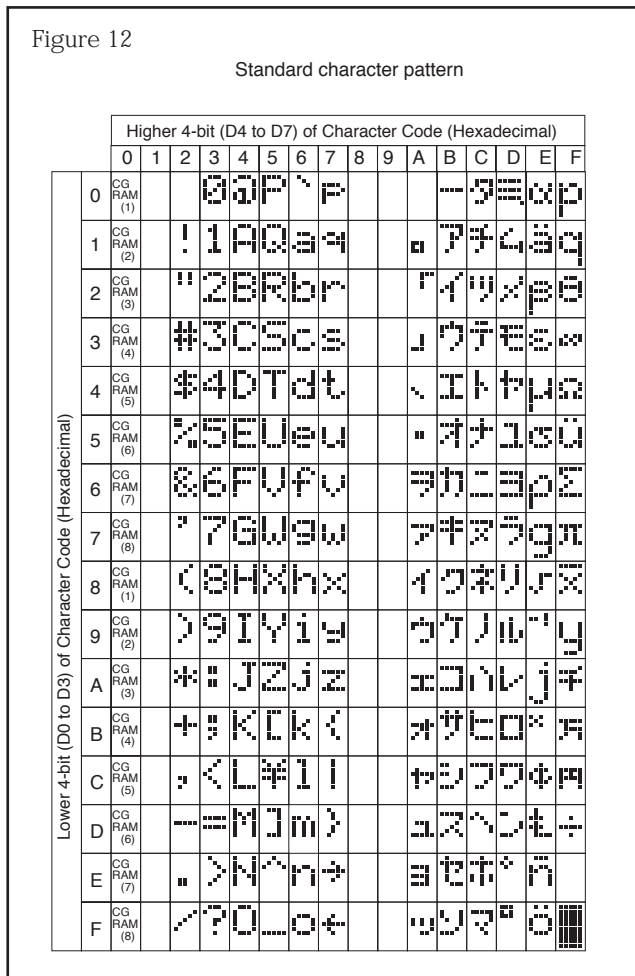

Power supply reset

The internal reset circuit will be operated properly when the following power supply conditions are satisfied. If it is not operated properly, please perform initial setting along with the instruction.

Item	Symbol	Measuring Condition	Standard value			Unit
			min.	typ.	max.	
Power supply rise time	trcc	-	0.1	-	10	mS
Power supply OFF time	toff	-	1	-	-	mS

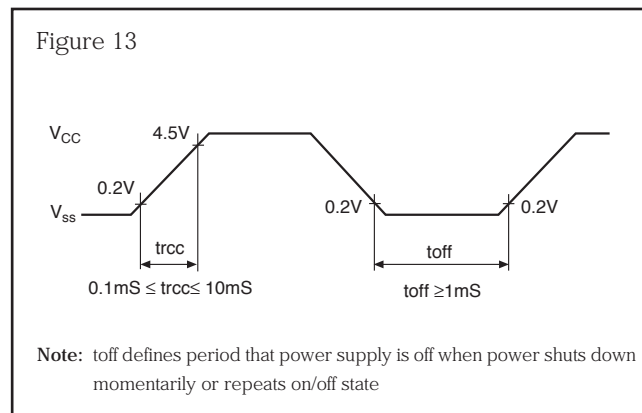

**Reset function**

● Initialisation made by Internal Rest Circuit  
 KS0066 automatically initialises (resets) when power is supplied (built-in internal reset circuit). The following instructions are executed in initialisation. The busy flag (BF) is kept in a busy state until initialisation ends. (BF=1) The busy state is 10ms after Vdd reach to 4.5V.

1. Display clear  
 DL = 1:8bit long interface data  
 DL = 0:4bit F=0:5 x dot character font  
 N =1: 2lines  
 N =0: 1line
2. Function set  
 D=0:display OFF C=0:cursor OFF B=0:blink OFF
3. Display ON/OFF control  
 D=0:display OFF C=0:cursor OFF B=0:blink OFF
4. Entry mode set  
 1/D=1: + 1 (increment) S=0:No shift

**Note:** When conditions stated in Power Supply Conditions Using Internal Reset Circuit are not satisfied, the internal reset circuit will not operate properly and initialisation will not be performed. Please make initialisation using MPU along with instructions.

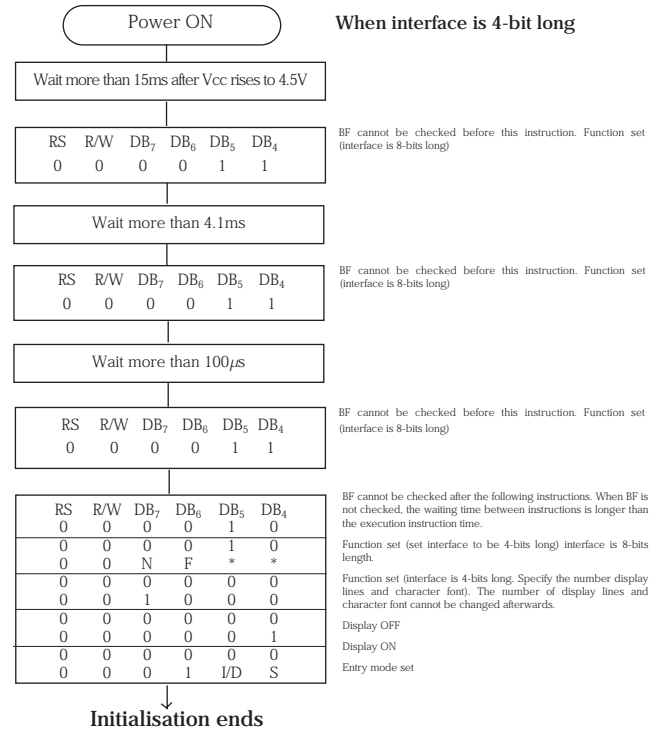

**Initialisation along with instructions**

If power supply conditions are not satisfied, for proper operation of internal reset circuit, it is required to make initialisation along with instruction. Please make following procedures:-

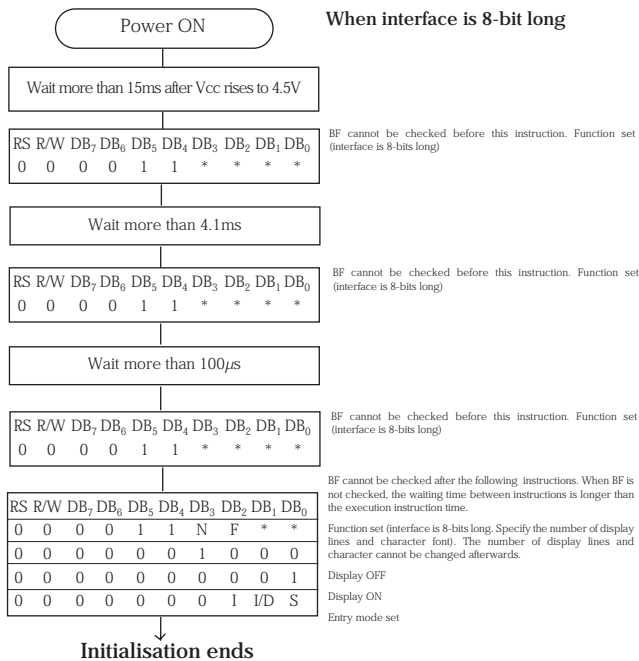

## Application example

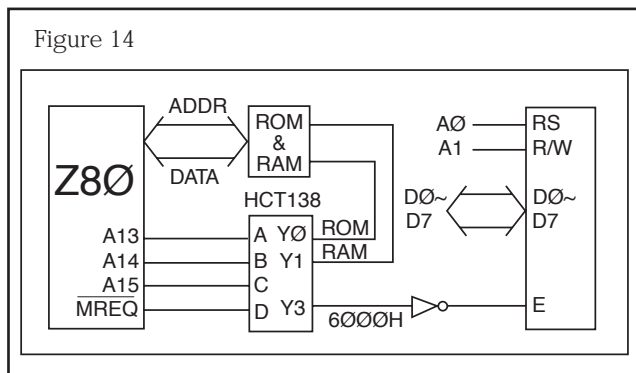

All modules except 20 x 4 and 40x4

Example of interfacing to Z80 MPU running at 2 Mhz

A0 is connected to **RS** of module

where A0 = 1: Instruction register is selected

where A0 = 0: Data register is selected

A1 is connected to R/W of module

where A1 = 0: Module in write mode

where A1 = 1: Module in read mode

```
WRINST EQU 6000H ;write instruction
WRDATA EQU 6001H ;write data
RDBUSY EQU 6002H ;read busy
```

**Initialisation**

```
LD B,0 ;power up delay
DJNZ $
LD SP,27FFH ;stack pointer
LD HL,INITBL ;init table pointer
LD B,15 ;15ms delay
CALL INSTR ;o/p instruction to module
LD B,5 ;5ms delay
CALL INSTR ;o/p instruction to module
LD B,1 ;one ms delay
CALL INSTR ;o/p instruction to module
```

**Function set**

function set

```
LD B,4 ;four modes
MODSET; CALL BUSY ;check for not busy
INC HL ;inc table pointer
LD A,(HL) ;get data
LD (WRINST),A ;and sent to module
DJNZ MODSET ;next mode
```

**Write message to module**

```
LD HL,MESSAGE ;get message table
;turn on display, blinking cursor
CALL BUSY
LD A,00001111B ;display on, cursor
LD (WRINST),A ;blink
;set DDRAM address to 00H
LD A,10000000B ;set to 00H
```

```
CALL MSG ;o/p message
;set DDRAM address to 40H
LD A,11000000B ;set to 40H
CALL MSG ;o/p message
HALT ;program stop here.....
```

```
;subroutine to set DDRAM addr and o/p message
```

```
MSG: CALL BUSY
LD (WRINST),A
;write message to module
LD B,8 ;no. of byte to be sent
WRITE2: CALL BUSY
LD A,(HL) ;get character
LD (WRDATA),A ;write to module
INC HL ;inc pointer
DJNZ WRITE2 ;next byte
RET
```

```
; subroutine : busy check
```

```
BUSY: PUSH AF
BUSY1: LD A,(RDBUSY)
BIT 7,A
JR NZ,BUSY1
POP AF
RET
```

```
;subroutine: o/p instruction to module
```

```
INSTR: CALL DELAY ;time delay
LD A,(HL) ;get data
LD (WRINST),A ;o/p to module
RET
```

```
; time delay subroutine
```

```
; Total delay time = B* 1mS
```

```
; Register destroyed : DE
```

```
DELAY: PUSH HL
LD DE,-1
LOOP1: LD HL,431/5
LOOP2: ADD HL,DE
JR C,LOOP2
DJNZ LOOP1
POP HL
RET
```

```
; data table for initialisation routine
```

```
INITBL: DEFB 00110000B ;set DL to high
DEFB 00111000B ;8-bit, 2 lines, 5X7 dots
DEFB 00001000B ;display off
DEFB 00000001B ;clear display, return cursor
DEFB 00000110B ;set shift mode (entry mode set)
```

```
; message
```

```
MSG: DEFB 'DISPLAY MODULES'
```

## Application example for 20 x 4 and 40 x 4 displays

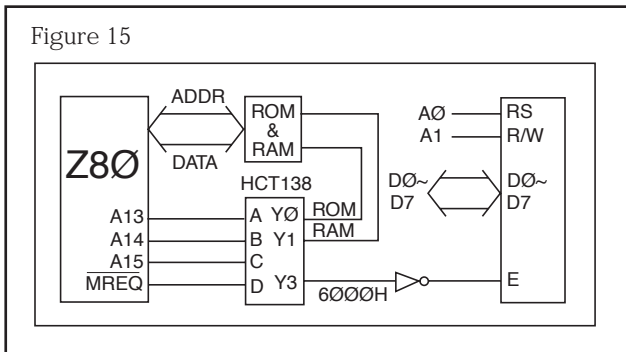

Example of interfacing to Z80 MPU running at 2 Mhz  
A0 is connected to RS of module

where A0 = 1: Instruction register is selected

where A0 = 0: Data register is selected

A1 is connected to R/W of module

where A1 = 0: Module in read mode

where A1 = 1: Module in write mode

```
WRINST EQU 6000H ;write instruction
WRDATA EQU 6001H ;write data
RDBUSY EQU 6002H ;read busy
```

**Initialisation**

```
LD B,0 ;power up delay
DJNZ $
LD SP,27FFH ;stack pointer
LD HL,INITBL ;init table pointer
LD B,15 ;15ms delay
CALL INSTR ;o/p instruction to module
LD B,5 ;5ms delay
CALL INSTR ;o/p instruction to module
```

**Function set**

```
LD B,1 ; one mS delay
CALL INSTR ;o/p instruction to module
```

**Function set**

```
; function set
LD B,4 ;four modes
MODSET: CALL BUSY ;check for not busy
INC HL ;inc table pointer
LD A,(HL) ;get data
LD (WRINST),A ;and sent to module
DJNZ MODSET ;next mode
```

**Write message to module**

```
; turn on display, blinking cursor
CALL BUSY
LD A,00001111B ;display on, cursor
LD (WRINST),A ;blink
;send message to display module
LD HL,MESSGE ;get message table
OUTMSG: LD A,(HL) ;get data from message table
```

```
CP $ ;is end of message ?
; JR Z,ENDMSG ;yes, it is
LD B,A ;no, this is the number
; of byte to be sent
INC HL ;now, get the DDRAM
; addr
LD A,(HL)
CALL BUSY ;check for not busy
SET 7,A ;set bit 7 to 1
LD (WRINST),A ;o/p to module
NXTCHR: INC HL ;get character
LD A,(HL)
CALL BUSY ;check for not busy
LD (WRDATA),A ;o/p to module
DJNZ NXTCHR ;o/p next character
INC HL ;inc pointer
JR OUTMSG ;go and check any
; more message
;
ENDMSG: HALT ;program stop here....
```

subroutine: busy check

```
BUSY: PUSH AF
BUSY1 LD A,(RDBUSY)
BIT 7,A
JR NZ,BUSY1
POP AF
RET
```

; SUBROUTINE : o/p instruction to module

```
INSTR: CALL DELAY ;time delay
LD A,(HL) ;get data
LD (WRINST),A ;o/p to module
RET
```

; time delay subroutine

; Total delay time = B \* 1mS

; Register destroyed : DE

```
DELAY: PUSH HL
LD DE,-1
LOOP1: LD HL,431/5
LOOP2: ADD HL,DE
JR C,LOOP2
DJNZ LOOP1
POP HL
RET
```

; data table for initialisation routine

```
INITBL: DEFB 00110000B ;set DL to high
DEFB 00111000B ;8 bit, 2 lines, 5x7 dots
DEFB 00001000B ;display off
DEFB 00000001B ;clear display, return
; cursor
DEFB 00000110B ;set shift mode
```

; message

```

MESSAGE:  DEFB  18    ;no. of character to be sent
           DEFB  00H   ;ADDR OF DDRAM
           DEFB  'This is first line'
           DEFB  19    ;no. of character to be sent
           DEFB  40H   ;addr of DDRAM
           DEFB  'This is second line'
           DEFB  18    ;no. of character to be sent
           DEFB  14H   ;addr of DDRAM
           DEFB  'This is third line'
           DEFB  19    ;no. of character to be sent
           DEFB  54H   ;addr of DDRAM
           DEFB  'This is fourth line'
           DEFB  '$'   ;end of message
           END
    
```

**EL**

Flat surface light source offers simple and even illumination over large area. It has an extremely thin structure type of illumination with little heat up.

**Features**

- Max. 1.3mm thickness (max. 1.5mm for lead portion)
- Wide driving condition of 60- 1,000Hz and 150Vac max., with inverter, step-up voltage from 1.5V battery is available
- Emitted colour is white
- Temperature range: operating 0°C ~ + 50°C  
Storage - 20°C ~ + 60°C

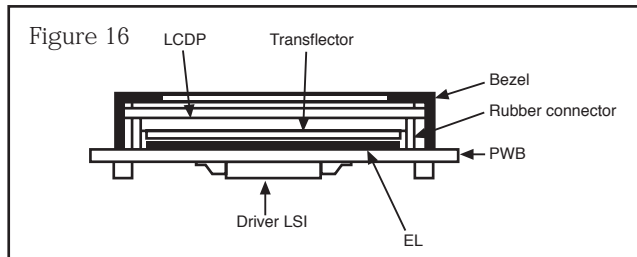

**Inverter for EL back light drive**

It is necessary to use inverter an when you need to operate EL with battery or a dc power supply.

- Low inverter loss and high light efficiency because it is designed as suitable for EL.
- Less change of power consumption during operation under temperature change or extended hours, which is realised by characteristics of constant supply current, minimises brightness change of EL.

**Inverter connections**

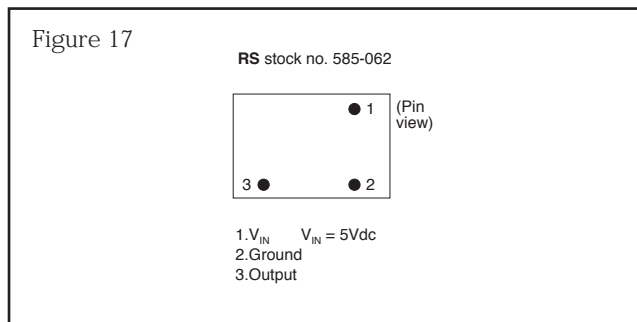

**Life characteristics**

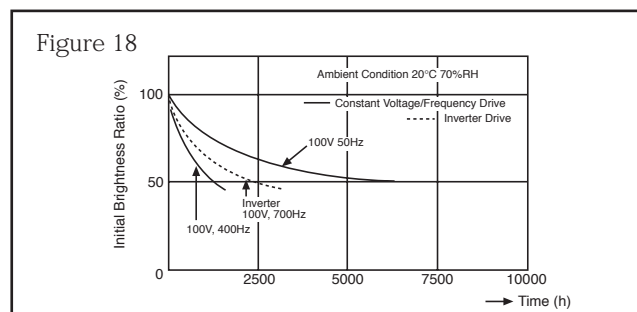

**Electrical characteristics (reference data)**

● Voltage VS. brightness

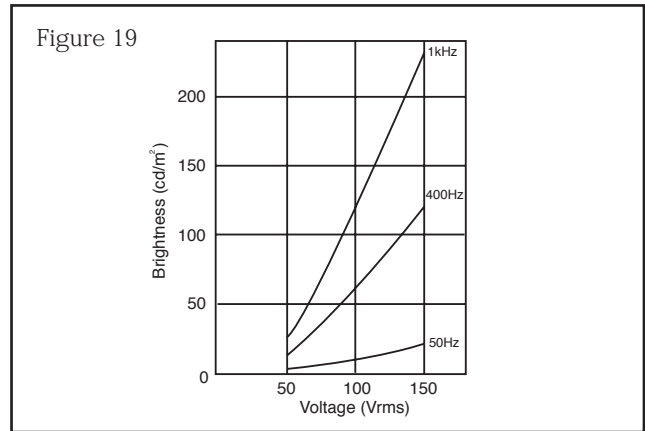

● Voltage VS. current density

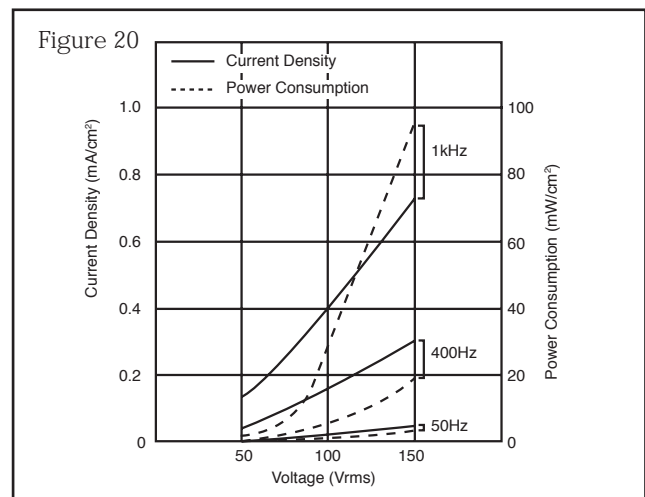

**LED backlight types**

**Features**

- Low voltage driving (dc) is available without inverter
- Long life time 100,000 hours (average)
- No noise occurrence.

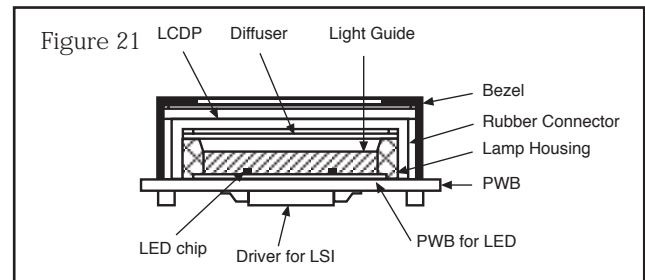

**Electrical characteristics (reference data)**

● Forward current derating curve

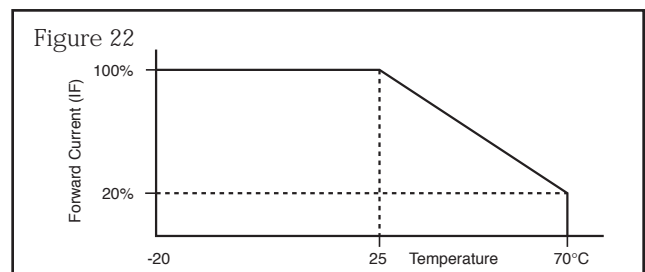

## Typical Problems

- Q. Why can only 1 character line be driven on a 2 character line module?  
 A. The module has either failed to initialise or has been initialised as a 1 line display
- Q. Why are some rows and/or columns of pixels missing?  
 A. The module has been mounted in way which is applying pressure to the bezel supporting the LCD glass.
- Q. Why does the display remain blank after initialisation and ASCII data sent?  
 A.  $V_{lcd}$  (V0) incorrectly set.  
 Timing incorrect. Check that all set up times have been followed. Check that the enable pulse width is 450nS minimum.
- Q. Why can only characters 1 to 8 be addressed on a one line by sixteen character module?  
 A. A 1 line by 16 character module must be treated electrically as a 2 line by 8 character display module. After initialisation Line 1 will address characters 1 to 8 (RAM address 00h to 07h) and Line 2 will address characters 9 to 16 (RAM address 40h to 47h)
- Q. Why can only lines 1 and 2 be addressed on a four line by forty character module?  
 A. The module contains two independent LCD controllers that must be driven as two separate 2 line by 40 character modules. The module has two enable lines allowing the top or bottom controller to be selected. If a hardware cursor is used it should be carefully controlled when moving between controllers.
- Q. When sequentially written data is sent to a 4 line by 16/20 module, why does the cursor jump from line 1 to line 3 to line 2 to line 4.  
 A. The module is electrically similar to a 2 line by forty module which has been folded in the middle such that line 3 follows line 1 and line 4 follows line 2.  
 Characters 1 to 20 are stored in RAM locations 00h to 13h  
 Characters 21 to 40 are stored in RAM locations 40h to 53h  
 Characters 41 to 60 are stored in RAM locations 14h to 27h  
 Characters 61 to 80 are stored in RAM locations 54h to 67h

## Mechanical dimensions

### 8 x 2 LCD modules

Figure 23

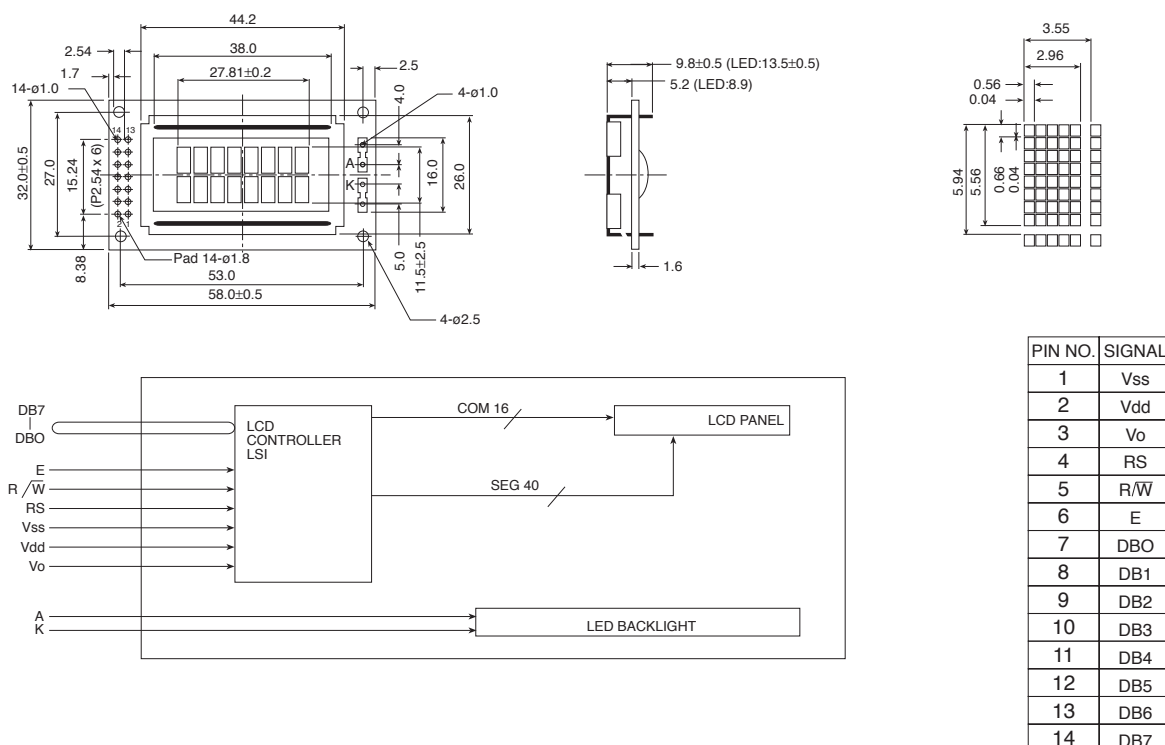

- RS** stock no. 214-3288 STN reflective  
**RS** stock no. 214-3367 TN with EL backlighting  
**RS** stock no. 214-3480 STN transfective with LED backlighting.

12 x 2 LCD module

Figure 24

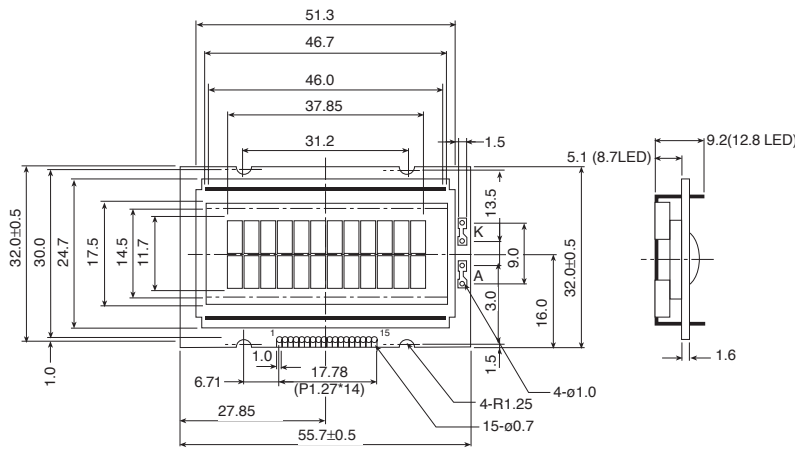

PIN NO.	SIGNAL
1	Vss
2	Vdd
3	Vo
4	RS
5	R/W
6	E
7	DB0
8	DB1
9	DB2
10	DB3
11	DB4
12	DB5
13	DB6
14	DB7
15	A

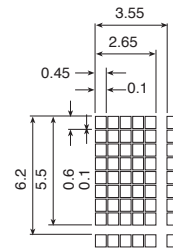
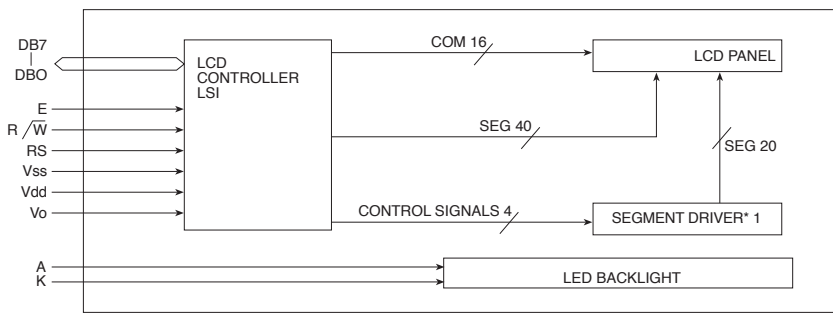

RS stock no. 294-8689 STN reflective

RS stock no. 214-3496 STN transfective with LED backlighting

16 x 1 Large Character LCD modules

Figure 25

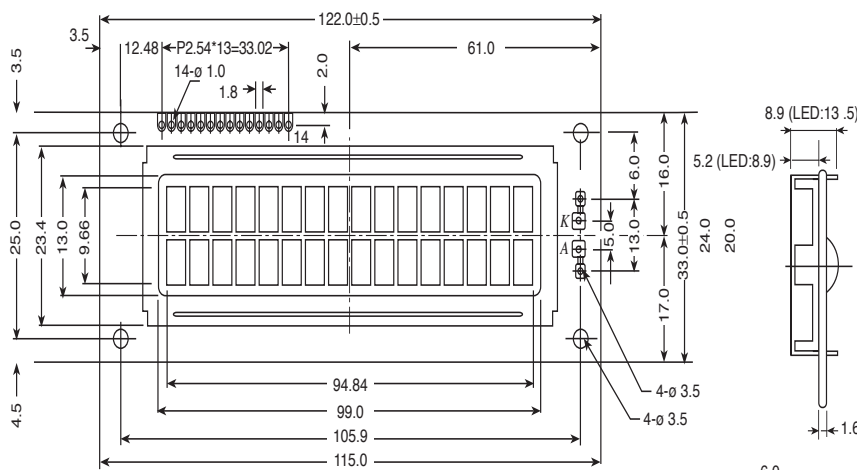

PIN NO.	SIGNAL
1	Vss
2	Vdd
3	Vo
4	RS
5	R/W
6	E
7	DB0
8	DB1
9	DB2
10	DB3
11	DB4
12	DB5
13	DB6
14	DB7
-	A
-	K

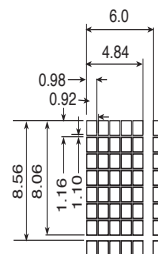
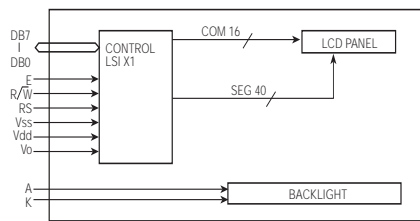

RS stock no. 294-8718 STN reflective

RS stock no. 294-8796 STN transfective with LED backlighting

16 x 1 LCD modules

Figure 26

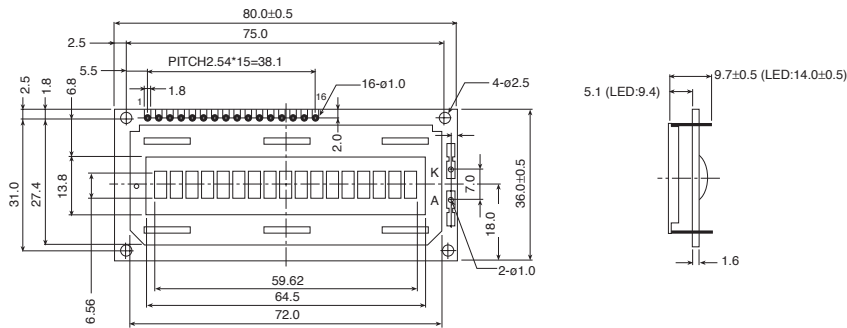

PIN NO.	SIGNAL
1	Vss
2	Vdd
3	Vo
4	RS
5	R/W
6	E
7	DBO
8	DB1
9	DB2
10	DB3
11	DB4
12	DB5
13	DB6
14	DB7
15	A
16	K

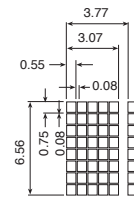
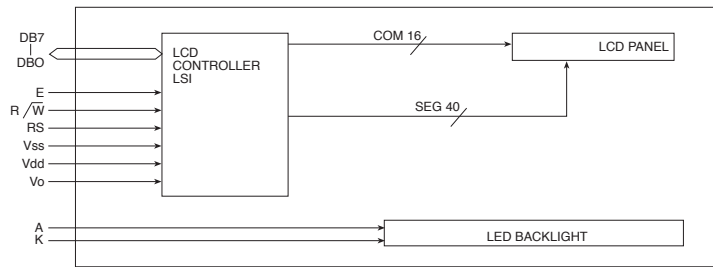

- RS stock no. 214-3238 TN reflective
- RS stock no. 214-3294 STN reflective
- RS stock no. 214-3373 TN with EL backlighting
- RS stock no. 214-3519 STN transfective with LED backlighting.

16 x 2 Small PCB LCD modules

Figure 27

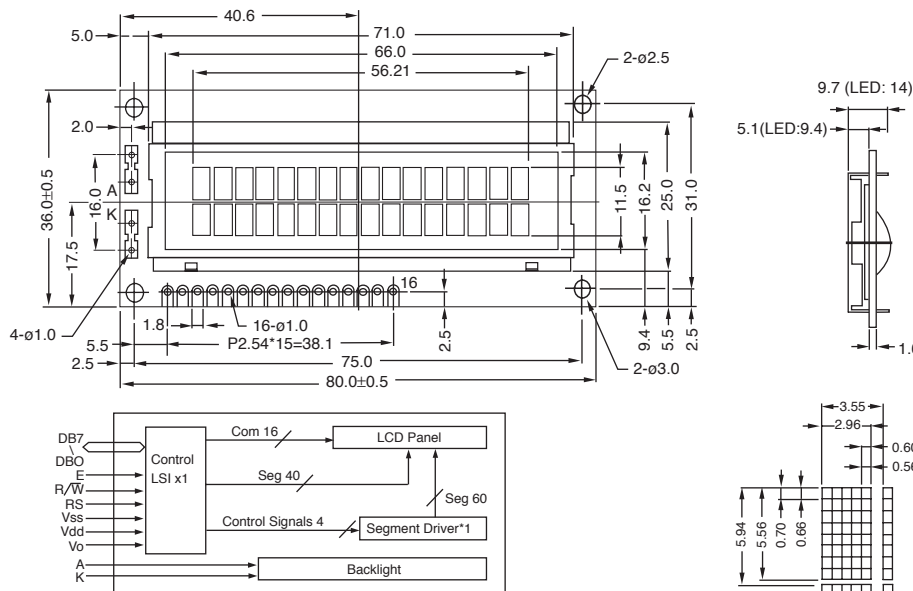

Pin no.	Signal
1	Vss
2	Vdd
3	Vo
4	RS
5	R/W
6	E
7	DBO
8	DB1
9	DB2
10	DB3
11	DB4
12	DB5
13	DB6
14	DB7
15	K
16	A

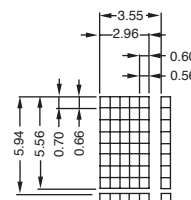
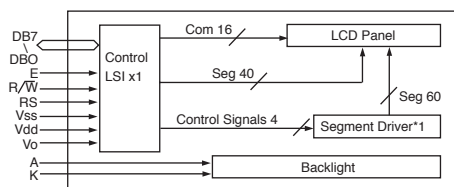

- RS stock no. 294-8667 TN reflective
- RS stock no. 294-8695 STN reflective
- RS stock no. 294-8774 STN transfective with LED backlighting

16 x 2 LCD modules

Figure 28

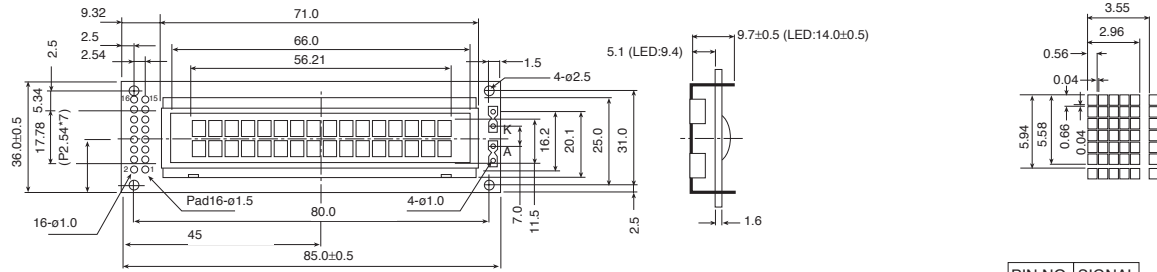

PIN NO.	SIGNAL
1	Vss
2	Vdd
3	Vo
4	RS
5	R/W
6	E
7	DBO
8	DB1
9	DB2
10	DB3
11	DB4
12	DB5
13	DB6
14	DB7
15	A
16	K

- RS stock no. 214-3244 TN reflective
- RS stock no. 214-3301 STN reflective
- RS stock no. 214-3395 TN with EL backlighting
- RS stock no. 214-3525 STN transfective with LED backlighting.

16x 2 Large Character LCD modules

Figure 29

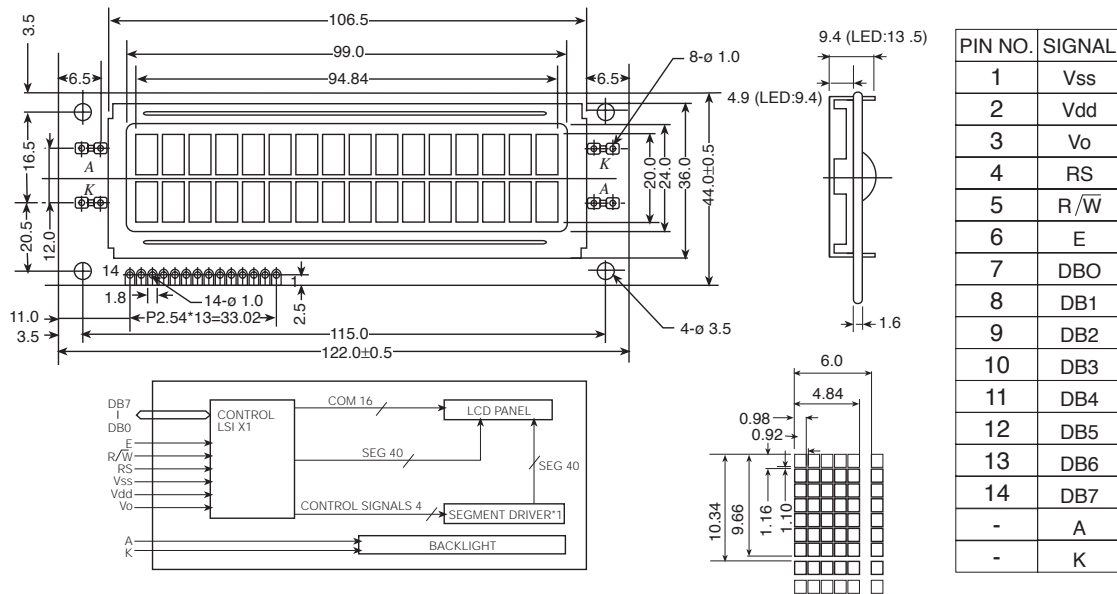

PIN NO.	SIGNAL
1	Vss
2	Vdd
3	Vo
4	RS
5	R/W
6	E
7	DBO
8	DB1
9	DB2
10	DB3
11	DB4
12	DB5
13	DB6
14	DB7
-	A
-	K

- RS stock no. 294-8724 STN reflective
- RS stock no. 294-8803 STN transfective with LED backlighting.

20 x 1 Large Character LCD modules

Figure 30

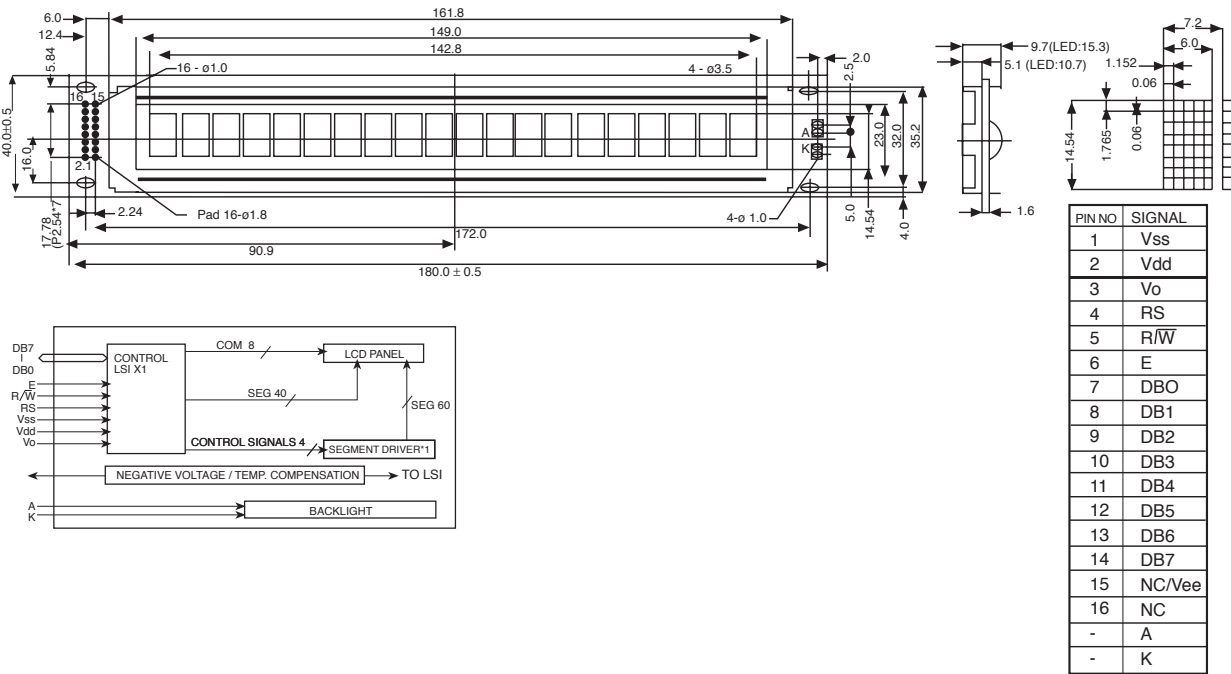

RS stock no. 294-8746 STN reflective  
 RS stock no. 214-3531 STN transfective with LED backlighting.

16 x 4 LCD modules

Figure 31

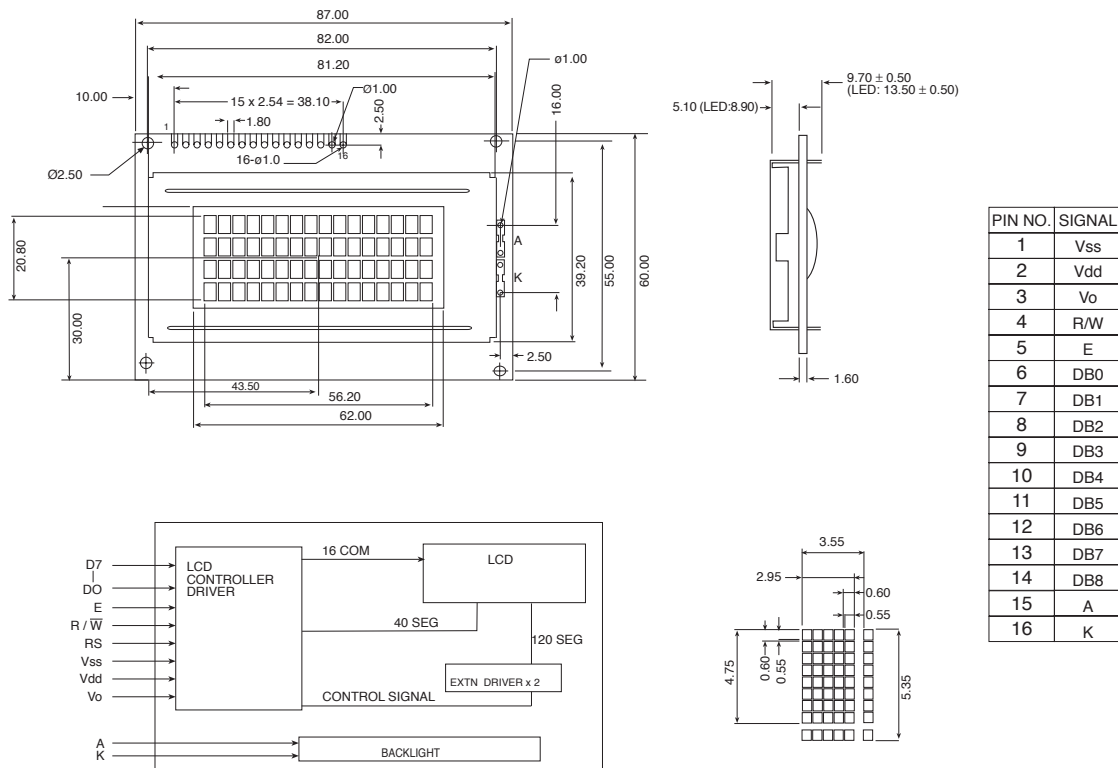

RS stock no. 294-8780 STN transfective with LED backlighting

20 x 2 LCD modules

Figure 32

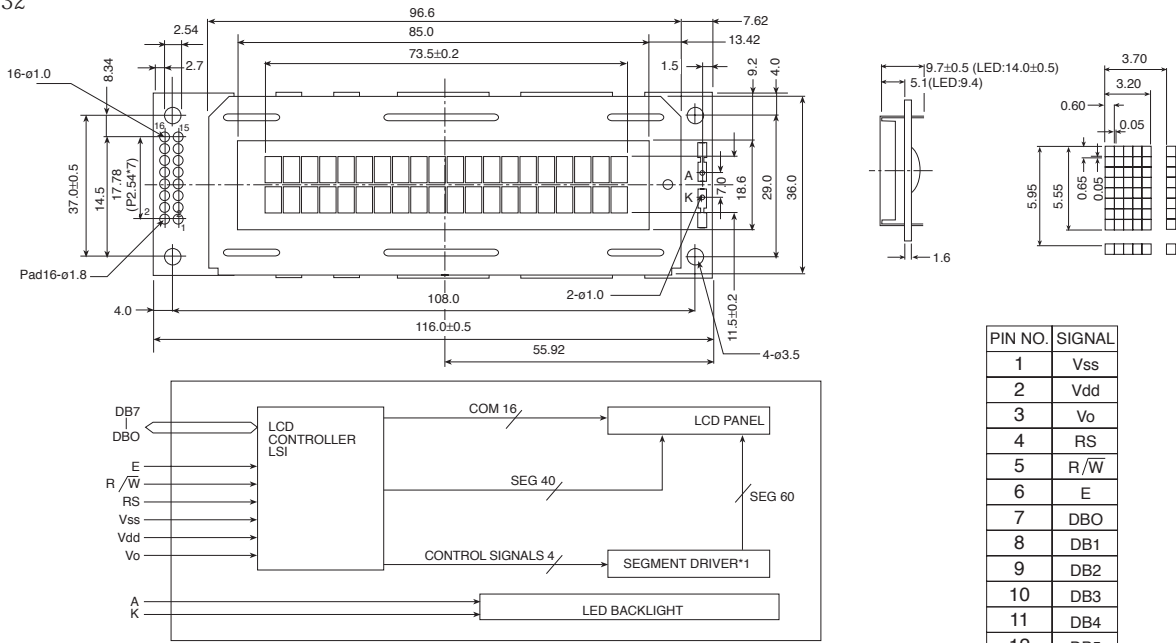

PIN NO.	SIGNAL
1	Vss
2	Vdd
3	Vo
4	RS
5	R/W
6	E
7	DBO
8	DB1
9	DB2
10	DB3
11	DB4
12	DB5
13	DB6
14	DB7
15	A
16	K

RS stock no. 214-3317 STN reflective

RS stock no. 214-3547 STN transfective with LED backlighting.

20 x 2 Large Character LCD modules

Figure 33

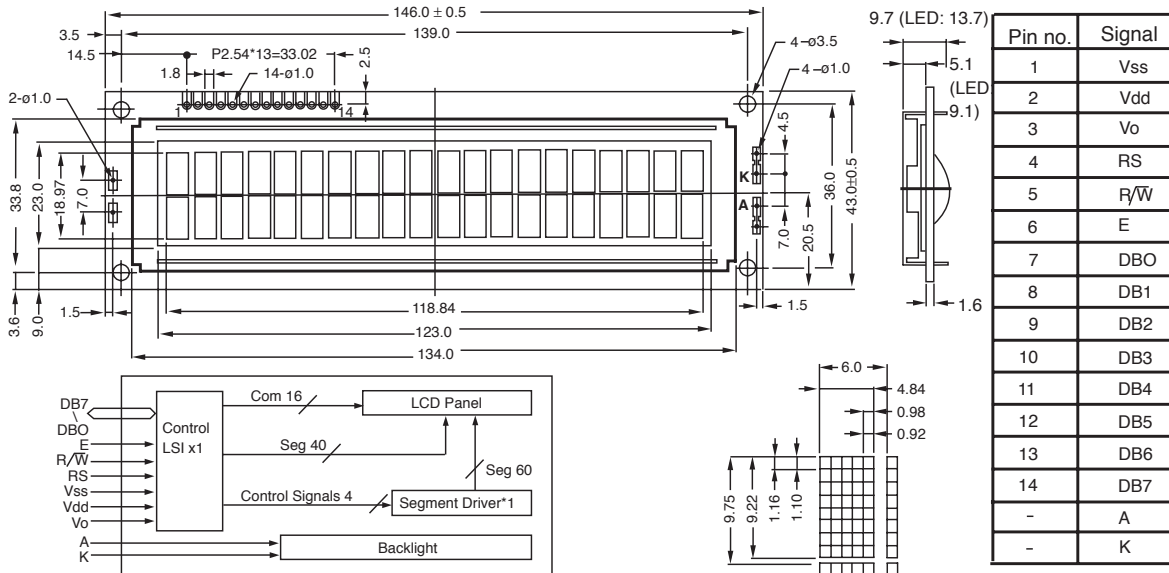

Pin no.	Signal
1	Vss
2	Vdd
3	Vo
4	RS
5	R/W
6	E
7	DBO
8	DB1
9	DB2
10	DB3
11	DB4
12	DB5
13	DB6
14	DB7
-	A
-	K

RS stock no. 294-8752 STN reflective

RS stock no. 294-8819 STN transfective with LED backlighting.

20 x 4 LCD modules

Figure 34

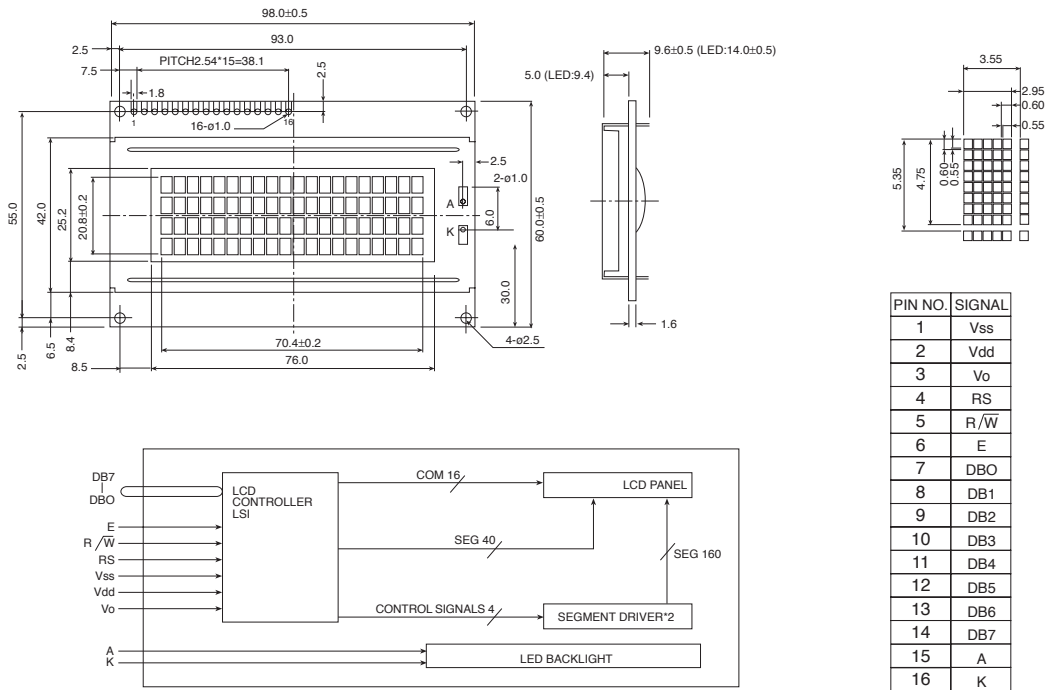

RS stock no. 214-3323 STN reflective  
 RS stock no. 214-3553 STN transfective with LED backlighting.

24 x 2 LCD modules

Figure 35

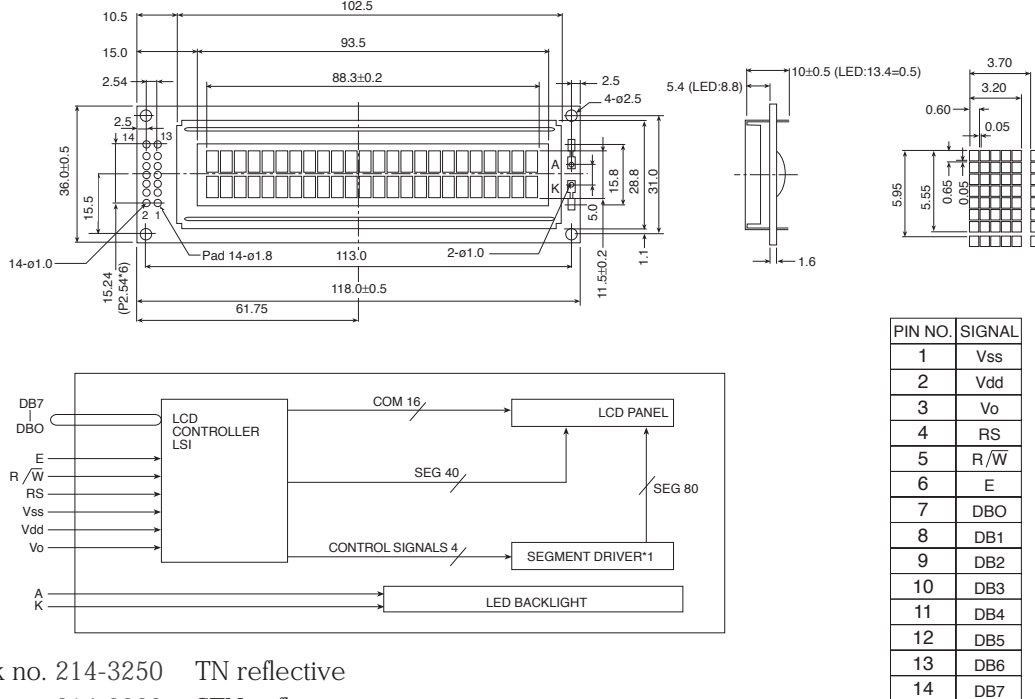

RS stock no. 214-3250 TN reflective  
 RS stock no. 214-3339 STN reflective  
 RS stock no. 214-3402 TN with EL backlighting  
 RS stock no. 214-3569 STN transfective with LED backlighting.

40 x 2 LCD modules

Figure 36

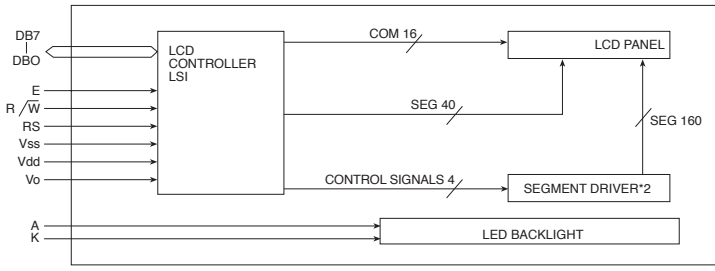
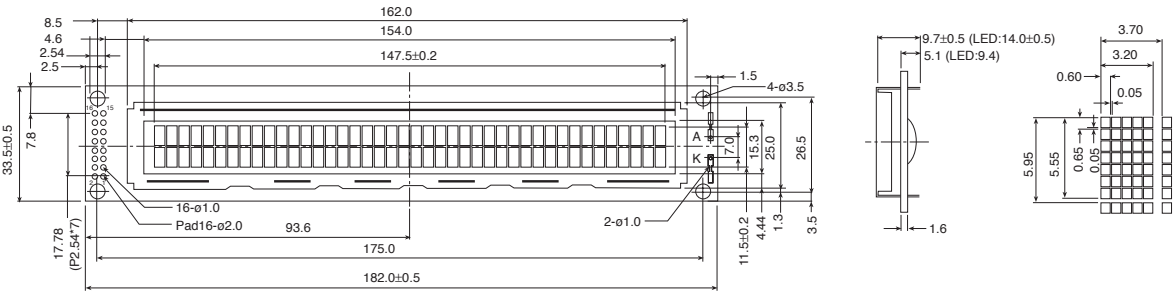

PIN NO.	SIGNAL
1	Vss
2	Vdd
3	Vo
4	RS
5	R/W
6	E
7	DBO
8	DB1
9	DB2
10	DB3
11	DB4
12	DB5
13	DB6
14	DB7
15	A
16	K

- RS stock no. 214-3266 TN reflective
- RS stock no. 214-3345 STN reflective
- RS stock no. 214-3418 TN with EL backlighting
- RS stock no. 214-3474 TN transmissive with LED backlighting
- RS stock no. 214-3575 STN transfective with LED backlighting.

40 x 4 LCD modules

Figure 37

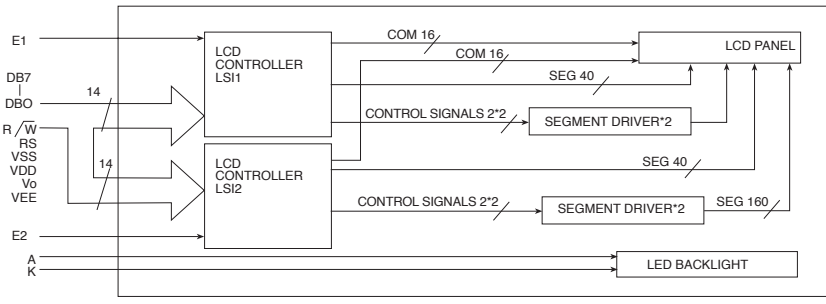
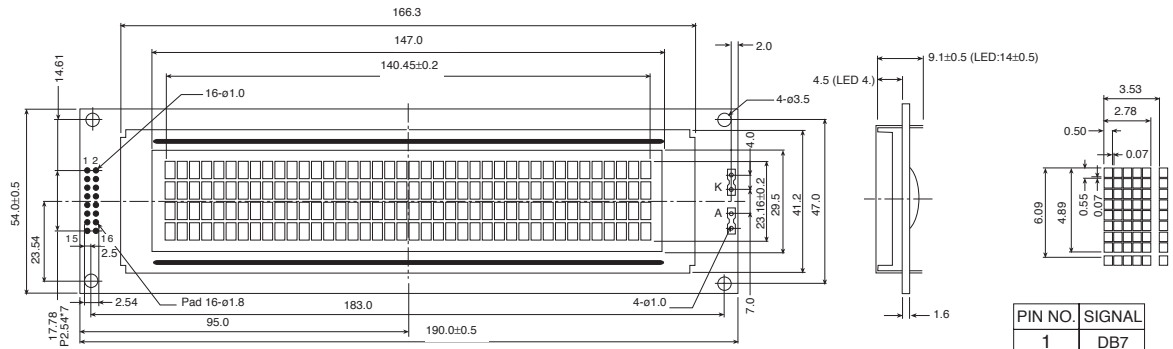

PIN NO.	SIGNAL
1	DB7
2	DB6
3	DB5
4	DB4
5	DB3
6	DB2
7	DB1
8	DB0
9	E1
10	R/W
11	RS
12	Vo
13	Vss
14	Vdd
15	E2
16	Vee

- RS stock no. 214-3272 TN reflective
- RS stock no. 214-3351 STN reflective
- RS stock no. 215-3617 STN transfective with LED backlighting

**Precaution for using**

## 1. Handling

- a) Do not touch, press or rub the display panel with a hard, stiff tool or object (e.g. tweezers) as the polariser in the panel are easily scratched.
- b) Never use organic solvents to clear the display panel as these solvents may adversely affect the polariser. To clean the display panel and dampen a bit of absorbent cotton with petroleum benzine and gently wipe the panel.
- c) Never touch terminals of electrodes of PCB or LSI leads.
- d) Avoid using or storing the LCM under high temperature and high humidity conditions. When in storage it is recommended that the device is packaged in a conductive polyethylene bag and placed under the condition where the temperature is relatively lower (10 -30°C), and direct sunlight or fluorescent lamp must be cut off.

## 2. Operation

- a) Never connect or disconnect the LCM from the main system while power is being supplied.
- b) If the operating temperature drops below the temperature limits, the blinking speed of the display will decrease, while if it rises above the prescribed limits, the entire display will turn black. When the temperature returns to within normal limits, the display will operate normally.

## 3. Workmanship

- a) Never disassemble the module.
- b) Anti static precautions must be taken, as the circuit of the module contains a CMOS LSI.

---

RS Components shall not be liable for any liability or loss of any nature (howsoever caused and whether or not due to RS Components' negligence) which may result from the use of any information provided in **RS** technical literature

---

RS Components, PO Box 99, Corby, Northants, NN17 9RS

 An Electrocomponents Company

Telephone: 01536 201234

© RS Components 1998